

STONE SINGLE

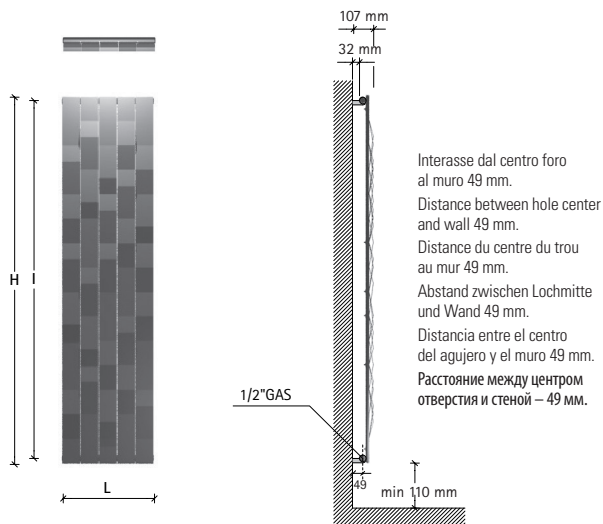

Interasse dal centro foro al muro 49 mm.
 Distance between hole center and wall 49 mm.
 Distance du centre du trou au mur 49 mm.
 Abstand zwischen Lochmitte und Wand 49 mm.
 Distancia entre el centro del agujero y el muro 49 mm.
 Расстояние между центром отверстия и стеной – 49 мм.

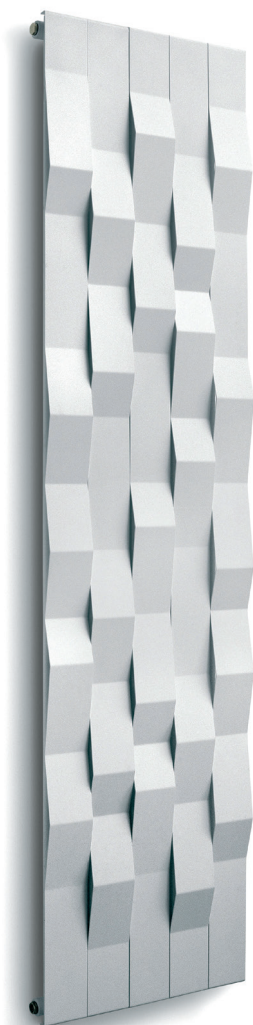

design by James Di Marco

coperture covers profilis de couverture Abdeckvingen cobertura Крышки	codice code Artikel Nr. codigo код	altezza height hauteur Höhe altura высота	larghezza width largeur Breite ancho ширина	interasse distance between bars entraxe Achsabstand distancia entre centros междцентровое расстояние	peso weight poids Gewicht peso вес	output мощность	Watt = Kcal/h ÷ 0,860 Kcal/h = Watt × 0,860	
							output мощность	output мощность
		H mm	L mm	I mm	Kg	75/65-20 watt* Δt50	55/45-20 watt* Δt30	55/45-24 watt* Δt26
3	F3ST01815...	1815	303	1760	21	544	286	239
	F3ST02010...	2015	303	1960	23	601	315	262
5	F5ST01815...	1815	503	1760	34	908	478	399
	F5ST02010...	2015	503	1960	37	1003	525	438
7	F7ST01815...	1815	703	1760	49	1270	669	559
	F7ST02010...	2015	703	1960	53	1401	733	612
Possibilità di realizzare larghezze personalizzate a richiesta . It is possible to produce custom-sizes radiators on request . Il est possible de produire hors dimensions sur demande .							Es ist möglich, die Heizkörper nach Maß zu fertigen Auf Anfrage . Posibilidad de realizar medidas personalizadas bajo pedido . По запросу возможно изготовление изделия с шириной по размерам заказчика.	

- * I watt hanno valori provvisori in attesa di certificazione Δt50.
- * The watt values are not definitive awaiting for Δt50 certification.
- * Le nombre de Watts est une valeur indiquée à titre provisoire dans l'attente de la certification Δt50.
- * Die Wattwerte sind noch provisorisch in Erwartung von Δt50 Zertifizierung.
- * Los Vattios tienen valores provisionales en espera de la certificación Δt50.
- * До получения сертификата Δt50 приводится предварительное значение мощности в ваттах.



Allacciamento 50 mm centrale per valvola remota a richiesta solo per SINGLE.
50 mm central connection for remote valve on request only for SINGLE.
Raccordement central 50 mm pour vanne à distance sur demande pour SINGLE seulement.
Mittelanschluss 50 mm für Fernventile Auf Anfrage nur für SINGLE.
Conexión central 50 mm para válvula remota bajo pedido solo para SINGLE.
50 мм центральное подключение с удаленными клапанами возможно по запросу только для одинарных радиаторов



STONE SINGLE

ALLACCIAMENTI IDRAULICI SPECIALI / SPECIAL CONNECTIONS / BRANCHEMENTS SPECIALS POSSIBLES / HYDRAULISCHE SONDERANSCHLÜSSE / EMPALMES HIDRAULICOS ESPECIALES / СПЕЦИАЛЬНЫЕ СОЕДИНЕНИЯ

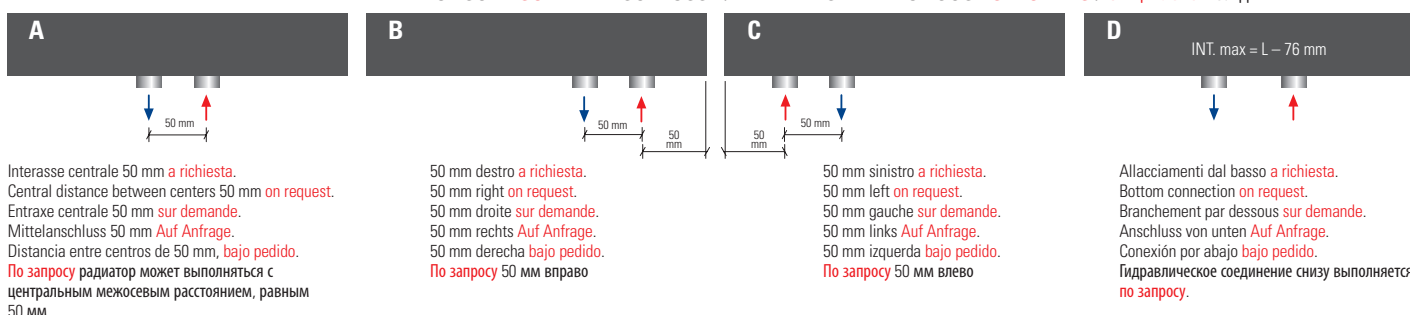

<p>I radiatori sono completi di kit di fissaggio a parete e valvola di sfogo. La barra portasciugamani estende la larghezza del radiatore di 18 mm. La versione cromata NON è disponibile. Pressione di collaudo: 10,5 bar Pressione di esercizio: 7 bar Materiale: Acciaio al carbonio</p>	<p>The radiators are equipped with a kit for fixing them to the wall and with an exhaust valve. The towel bar makes the radiator 18 mm larger. Chromed version is NOT available. Testing pressure: 10,5 bar Working pressure: 7 bar. Material: carbon-steel</p>	<p>Les radiateurs sont munis d'un kit de fixation murale et d'une soupape de décompression. Avec la barre porte-serviettes le radiateur est 18 mm plus large. La version chromée N'EST PAS disponible. Pression d'essai: 10,5 bars Pression d'exercice: 7 bars Matière: Acier au charbon</p>	<p>Die Heizkörper sind mit Wandbefestigungsset und Luftventil ausgerüstet. Mit Handtuchhalter ist der Heizkörper 18 mm breiter. Die verchromte Version ist NICHT verfügbar. Prüfungsdruck: 10,5 bar Betriebsdruck: 7 bar Stoff: Kohlenstoffstahl</p>	<p>Los radiadores están provistos de kit de fijación a la pared y de válvula de desahogo. La barra portatoallas extiende la longitud del radiador de 18 mm. La versión cromada NO está disponible. Presión de ensayo: 10,5 bar Presión de trabajo: 7 bar Material: Acero de carbon</p>	<p>Радиаторы укомплектованы набором крепежных деталей для закрепления на стене и выпускным клапаном. Переключатель для полотенца увеличивает ширину радиатора на 18 мм. Хромированная версия в продаже ОТСУТСТВУЕТ. Давление при испытании – 10,5 бар Рабочее давление – 7 бар Под заказ радиаторы могут проходить испытание при 16 бар в случае рабочего давления 12 бар. Повышение цен на 7%. Материал – углеродистая сталь</p>
------------------------------------------------------------------------------------------------------------------------------------------------------------------------------------------------------------------------------------------------------------------------------------------------------------------------	--------------------------------------------------------------------------------------------------------------------------------------------------------------------------------------------------------------------------------------------------------------------------------------------	-------------------------------------------------------------------------------------------------------------------------------------------------------------------------------------------------------------------------------------------------------------------------------------------------------------------------	---------------------------------------------------------------------------------------------------------------------------------------------------------------------------------------------------------------------------------------------------------------------------------	-------------------------------------------------------------------------------------------------------------------------------------------------------------------------------------------------------------------------------------------------------------------------------------------------------------------	----------------------------------------------------------------------------------------------------------------------------------------------------------------------------------------------------------------------------------------------------------------------------------------------------------------------------------------------------------------------------------------------------------------------------------------------------------------------

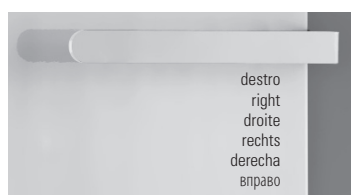
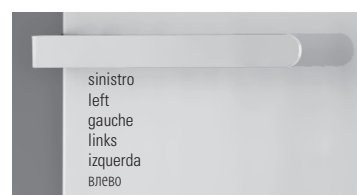

Barra portasciugamani short a richiesta.
Short towel rail on request.
Barre porte-serviettes short sur demande.
Handtuchtrockenstange Short Auf Anfrage.
Barra calentatoallas short bajo pedido.
По запросу изготавливается переключатель для полотенца модели Short.
p./S. 222

STONE SINGLE ELEC

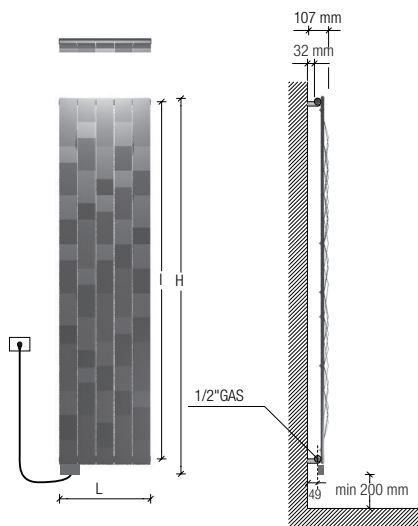

Interasse dal centro foro al muro 49 mm.
Distance between hole center and wall 49 mm.
Distance du centre du trou au mur 49 mm.
Abstand zwischen Lochmitte und Wand 49 mm.
Distancia entre el centro del agujero y el muro 49 mm.
Расстояние между центром отверстия и стеной – 49 мм.

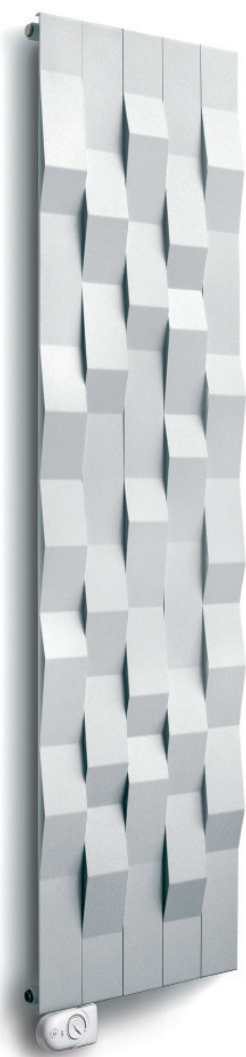

design by James Di Marco



Resistenza solo a sinistra e inserita verticalmente nel radiatore.
Electric element only on the left side and inserted vertically into the radiator.
Resistance électrique seulement à gauche et insérée verticalement dans le radiateur.
Heizpatrone nur links und im Heizkörper vertikal eingesetzt.
Resistencia sólo a la izquierda y insertada verticalmente en el radiador.
Электротен только слева и расположен вертикально в радиаторе.



H1 / H2

NEWS

Resistenza elettrica con costo aggiuntivo del 3%
potenza elettrica resistenza **MAX 1000watt**
Electric resistance with additional cost 3%
output for electrical version **MAX 1000watt**
Resistance électrique avec coût supplémentaire 3%
puissance en version électrique **MAX 1000watt**
Heizstab mit Mehrpreis 3%
Leistung der elektrischen Ausführung **MAX 1000watt**
Resistencia eléctrica con costo adicional 3%
output version eléctrica **MAX 1000watt**
Электрическое сопротивление за дополнительную плату 3%
мощность электрического варианта **MAX 1000watt**

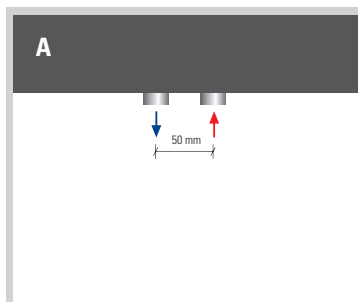

A

Interasse Centrale 50 mm **a richiesta**. A partire da L 503.
Central distance between centers 50 mm **on request**. From L 503.
Entraxe centrale 50 mm **sur demande**. À partir de L 503.
Mittelanschluss 50 mm **Auf Anfrage**. Ab L 503.
Distancia entre centros de 50 mm, **bajo pedido**. A partir de L 503.
По запросу радиатор может выполняться с центральным межосевым расстоянием, равным 50 мм. От длины L 503.

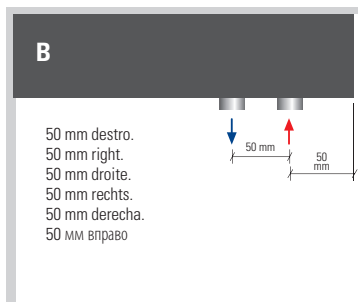

B

50 mm destro.
50 mm right.
50 mm droite.
50 mm rechts.
50 mm derecha.
50 мм вправо

Interasse Destro 50 mm **a richiesta**.
Right distance between centers 50 mm **on request**.
Entraxe Droite 50 mm **sur demande**.
Rechtsanschluss 50 mm **Auf Anfrage**.
Distancia entre Derecha de 50 mm, **bajo pedido**.
По запросу радиатор может выполняться с право межосевым расстоянием, равным 50 мм.

STONE SINGLE ELEC

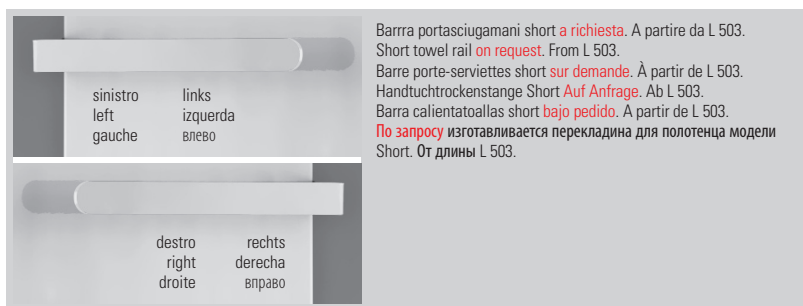

copertura covers profil di copertura Abdeckvingen cobertura Крышки	codice code Artikel Nr. codigo код	altezza* height* hauteur* Höhe* altura* высота*	larghezza width largeur Breite ancho ширина	interasse distance between bars entraxe Achsabstand distancia entre centros межцентровое расстояние	peso radiatore + glicole weight of radiator + glycole poids du radiateur + glycol Gewicht inkl. Glykol peso radiador + glycole вес радиатор + гликоль	output versione idraulica output for electrical version puissance en version eau chaude Leistung der Wasserausführung output version agua calda мощность гидравлического варианта	potenza elettrica resistenza output for electrical version puissance en version électrique Leistung der elektrischen Ausführung output version eléctrica мощность электрического варианта
		H mm	L mm	I mm	Kg	$\Delta t50$ watt*	watt*
	F3ST01815...	1925	303	1760	26	544	700
	F3ST02015...	2125	303	1960	28	601	1000
	F5ST01815...	1925	503	1760	42	908	1000
	F5ST02015...	2125	503	1960	45	1003	1400
	F7ST01815...	1925	703	1760	59	1270	1400
	F7ST02015...	2125	703	1960	63	1401	1700

- * I watt hanno valori provvisori in attesa di certificazione $\Delta t50$.
- * The watt values are not definitive awaiting for $\Delta t50$ certification.
- * Le nombre de Watts est une valeur indiquée à titre provisoire dans l'attente de la certification $\Delta t50$.
- * Die Wattwerte sind noch provisorisch in Erwartung von $\Delta t50$ Zertifizierung.
- * Los Vattios tienen valores provisionales en espera de la certificación $\Delta t50$.
- * До получения сертификата $\Delta t50$ приводится предварительное значение мощности в ваттах.

<ul style="list-style-type: none"> • Incluso il termostato analogico di 110 mm • Included 110 mm high analogic room control • Inclus boîtier de régulation analogique de 110 mm • Inkl. Raumthermostat (110 mm) • Includo termostato por ambiente analogico de 110 mm • Включаю аналоговый термостат 110 мм 	<p>Scatola termostato bianca di serie per radiatori bianchi. Scatola termostato cromata di serie per radiatori colorati. Standard white thermostat box for white radiators. Standard chromed thermostat box for coloured radiators. Boîtier thermostat blanc de série pour radiateurs blancs. Boîtier thermostat chromée de série pour radiateurs colorés. Serienmäßig weißes Thermostatgehäuse für weiße Heizkörper. Serienmäßig verchromte Thermostatgehäuse für bunte Heizkörper. Caja de termostato blanca de serie para radiadores blancos. Caja de termostato cromado de serie para radiadores coloreados. Корпус термостата белый стандартный для белых радиаторов. Корпус термостата серый матовый стандартный для цветного радиатора</p>
-------------------------------------------------------------------------------------------------------------------------------------------------------------------------------------------------------------------------------------------------------------------------------------------------------------------------------------------------------------------------	-----------------------------------------------------------------------------------------------------------------------------------------------------------------------------------------------------------------------------------------------------------------------------------------------------------------------------------------------------------------------------------------------------------------------------------------------------------------------------------------------------------------------------------------------------------------------------------------------------------------------------------------------------------------------------------------------------------------------------------------------------------------------

<p>I radiatori sono completi di kit di fissaggio a parete e valvola di sfogo. La barra porta asciugamano estende la larghezza del radiatore di 20/40 mm. La versione cromata NON è disponibile. Pressione di collaudo: 10,5 bar Pressione di esercizio: 7 bar Materiale: Acciaio al carbonio</p>	<p>The radiators are equipped with a kit for fixing them to the wall and with an exhaust valve. The towel bar makes the radiator 20/40 mm larger. Chromed radiators NOT available. Testing pressure: 10,5 bar Working pressure: 7 bar Material: carbon-steel</p>	<p>Les radiateurs sont munis d'un kit de fixation murale et d'une soupape de décompression. Avec la barre porte-serviettes le radiateur est 20/40 mm plus large. La version chromée N'EST PAS disponible. Pression d'essai: 10,5 bars Pression d'exercice: 7 bars Matière: Acier au charbon</p>	<p>Die Heizkörper sind mit Wandbefestigungsset und Luftventil ausgerüstet. Mit Handtuchhalter ist der Heizkörper 20/40 mm breiter. Die verchromte Version ist NICHT verfügbar. Prüfungsdruck: 10,5 bar Betriebsdruck: 7 bar Stoff: Kohlenstoffstahl</p>	<p>Los radiadores están provistos de kit de fijación a la pared y de válvula de desahogo. La barra portatoallas extiende la longitud del radiador de 20/40 mm. La versión cromada NO está disponible. Presión de ensayo: 10,5 bar Presión de trabajo: 7 bar Material: Acero de carbono</p>	<p>Радіатори укомплектовані набором кріпильних деталей для закріплення на стіні і випускним клапаном. Перекладина для полотенця збільшує ширину радіатора на 20/40 мм. Хромована версія в продажі ОТСУТСТВУЄ. Давлення при испытании – 10,5 бар Рабочее давление – 7 бар Под заказ радиаторы могут проходить испытание при 16 бар в случае рабочего давления 12 бар. Повышение цен на 7%. Материал – углеродистая сталь</p>
-----------------------------------------------------------------------------------------------------------------------------------------------------------------------------------------------------------------------------------------------------------------------------------------------------------------------------	---------------------------------------------------------------------------------------------------------------------------------------------------------------------------------------------------------------------------------------------------------------------------------------------	----------------------------------------------------------------------------------------------------------------------------------------------------------------------------------------------------------------------------------------------------------------------------------------------------------------------------	------------------------------------------------------------------------------------------------------------------------------------------------------------------------------------------------------------------------------------------------------------------------------------	-----------------------------------------------------------------------------------------------------------------------------------------------------------------------------------------------------------------------------------------------------------------------------------------------------------------------	----------------------------------------------------------------------------------------------------------------------------------------------------------------------------------------------------------------------------------------------------------------------------------------------------------------------------------------------------------------------------------------------------------------------------------------------------------------

STONE DOUBLE

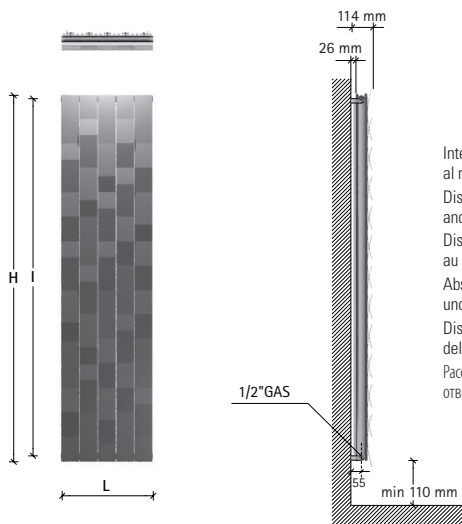

Interasse dal centro foro al muro 55 mm.
Distance between hole center and wall 55 mm.
Distance du centre du trou au mur 55 mm.
Abstand zwischen Lochmitte und Wand 55 mm.
Distancia entre el centro del agujero y el muro 55 mm.
Расстояние между центром отверстия и стеной – 55 мм.

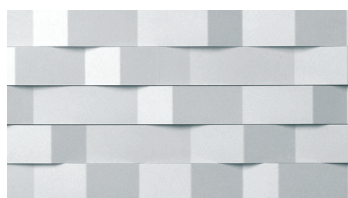

A richiesta il modello Stone può essere previsto per il montaggio in orizzontale con maggiorazione del 7%.
On request Stone can be produced for being mounting horizontally with 7% price surcharge
Sur demande Stone peut être prévu pour l'installation en horizontal avec majoration du prix du 7%
Auf Anfrage kann Stone gefertigt werden, um es horizontal zu montieren. Mehrpreis von 7%.
Bajo pedido el modelo Stone puede ser previsto por el montaje en horizontal con aumento de 7%.
По запросу модель Stone может быть выполнена для монтажа в горизонтальном положении, при этом предусматривается увеличение цены на 7%.



coperture covers profili de couverture Abdeckvingen cobertura Крышки	codice code code Artikel Nr. codigo код	altezza height hauteur Breite altura высота	larghezza width largeur Breite ancha ширина	interasse distance between bars entraxe Achsabstand distancia entre centros межцентровое расстояние	peso weight poids Gewicht peso вес	output мощность watt*	Watt = Kcal/h = 0,860 Kcal/h = Watt x 0,860	
							output мощность watt*	output мощность watt*
		H mm	L mm	I mm	Kg	Δt50	Δt30	Δt26
3	F3ST01815...	1815	303	1760	33	809	410	339
	F3ST02010...	2015	303	1960	37	893	451	372
5	F5ST01815...	1815	503	1760	54	1348	683	565
	F5ST02010...	2015	503	1960	59	1489	752	621
7	F7ST01815...	1815	703	1760	76	1888	957	791
	F7ST02010...	2015	703	1960	83	2084	1052	869
...	Possibilità di realizzare larghezze personalizzate a richiesta . It is possible to produce custom-sizes radiators on request . Il est possible de produire hors dimensions sur demande .					Es ist möglich, die Heizkörper nach Maß zu fertigen Auf Anfrage . Posibilidad de realizar medidas personalizadas bajo pedido . По запросу возможно изготовление изделия с шириной по размерам заказчика.		

- * I watt hanno valori provvisori in attesa di certificazione Δt50.
- * The watt values are not definitive awaiting for Δt50 certification.
- * Le nombre de Watts est une valeur indiquée à titre provisoire dans l'attente de la certification Δt50.
- * Die Wattwerte sind noch provisorisch in Erwartung von Δt50 Zertifizierung.
- * Los Varios tienen valores provisionales en espera de la certificación Δt50.
- * До получения сертификата Δt50 приводится предварительное значение мощности в ваттах.

STONE DOUBLE

ALLACCIAMENTI IDRAULICI **SPECIALI** / **SPECIAL CONNECTIONS** / BRANCHEMENTS **SPECIALS** POSSIBLES / HYDRAULISCHE **SONDERANSCHLÜSSE** / EMPALMES HYDRAULICOS **ESPECIALES** / **СПЕЦИАЛЬНЫЕ СОЕДИНЕНИЯ**

A

Interasse centrale 50 mm **a richiesta**.
Central distance between centers 50 mm **on request**.
Entraxe centrale 50 mm **sur demande**.
Mittelanschluss 50 mm **Auf Anfrage**.
Distancia entre centros de 50 mm, **bajo pedido**.
По запросу радиатор может выполняться с центральным межосевым расстоянием, равным 50 мм.

B

50 mm destro **a richiesta**.
50 mm right **on request**.
50 mm droite **sur demande**.
50 mm rechts **Auf Anfrage**.
50 mm derecha **bajo pedido**.
По запросу 50 мм вправо

C

50 mm sinistro **a richiesta**.
50 mm left **on request**.
50 mm gauche **sur demande**.
50 mm links **Auf Anfrage**.
50 mm izquierda **bajo pedido**.
По запросу 50 мм влево

D

Allacciamenti dal basso **a richiesta**.
Bottom connection **on request**.
Branchement par dessous **sur demande**.
Anschluss von unten **Auf Anfrage**.
Conexión por abajo **bajo pedido**.
Гидравлическое соединение снизу выполняется **по запросу**.

<p>I radiatori sono completi di kit di fissaggio a parete e valvola di sfogo. La barra porta asciugamano estende la larghezza del radiatore di 18 mm. La versione cromata NON è disponibile. Pressione di collaudo: 10,5 bar Pressione di esercizio: 7 bar Materiale: Acciaio al carbonio</p>	<p>The radiators are equipped with a kit for fixing them to the wall and with an exhaust valve. The towel bar makes the radiator 18 mm larger. Chromed version is NOT available. Testing pressure: 10,5 bar Working pressure: 7 bar Material: carbon-steel</p>	<p>Les radiateurs sont munis d'un kit de fixation murale et d'une soupape de décompression. Avec la barre porte-serviettes le radiateur est 18 mm plus large. La version chromée N'EST PAS disponible. Pression d'essai: 10,5 bars Pression d'exercice: 7 bars Matière: Acier au charbon</p>	<p>Die Heizkörper sind mit Wandbefestigungssset und Luftventil ausgerüstet. Mit Handtuchhalter ist der Heizkörper 18 mm breiter. Die verchromte Version ist NICHT verfügbar. Prüfungsdruck: 10,5 bar Betriebsdruck: 7 bar Stoff: Kohlenstoffstahl</p>	<p>Los radiadores están provistos de kit de fijación a la pared y de válvula de desahogo. La barra portatoallas extiende la longitud del radiador de 18 mm. La versión cromada NO está disponible. Presión de ensayo: 10,5 bar Presión de trabajo: 7 bar Material: Acero de carbon</p>	<p>Радиаторы укомплектованы набором крепежных деталей для закрепления на стене и выпускным клапаном. Перекладина для полотенец увеличивает ширину радиатора на 18 мм. Хромированная версия в продаже ОТСУТСТВУЕТ. Давление при испытании – 10,5 бар Рабочее давление – 7 бар Под заказ радиаторы могут проходить испытание при 16 бар в случае рабочего давления 12 бар. Повышение цен на 7%. Материал – углеродистая сталь</p>
---------------------------------------------------------------------------------------------------------------------------------------------------------------------------------------------------------------------------------------------------------------------------------------------------------------------------------	--------------------------------------------------------------------------------------------------------------------------------------------------------------------------------------------------------------------------------------------------------------------------------------------------	--------------------------------------------------------------------------------------------------------------------------------------------------------------------------------------------------------------------------------------------------------------------------------------------------------------------------------	-----------------------------------------------------------------------------------------------------------------------------------------------------------------------------------------------------------------------------------------------------------------------------------------	--------------------------------------------------------------------------------------------------------------------------------------------------------------------------------------------------------------------------------------------------------------------------------------------------------------------------	----------------------------------------------------------------------------------------------------------------------------------------------------------------------------------------------------------------------------------------------------------------------------------------------------------------------------------------------------------------------------------------------------------------------------------------------------------------------------------