

# CIVETTA 35 SINGLE

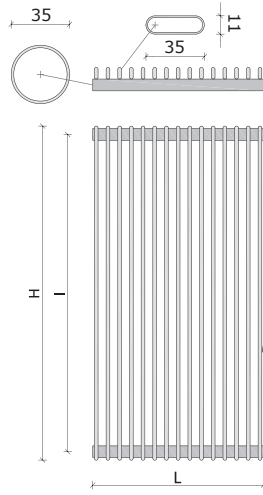

tubi min 4 / max 38  
 pipes min 4 / max 38  
 tuyaux min 4 / max 38  
 rohre min 4 / max 38  
 tubos min 4 / max 38  
 трубы мин. 4 / макс. 38

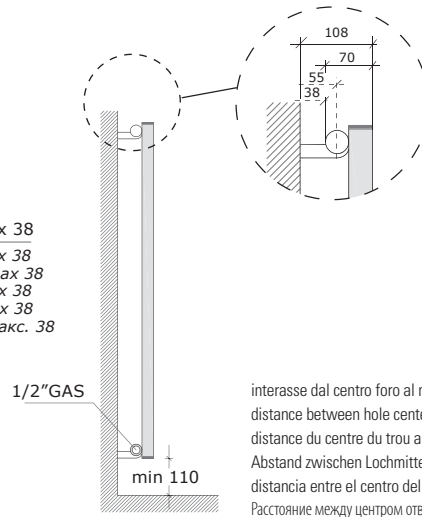

interasse dal centro foro al muro 55 mm  
 distance between hole center and wall 55 mm  
 distance du centre du trou au mur 55 mm  
 Abstand zwischen Lochmitte und Wand 55 mm  
 distancia entre el centro del agujero y el muro 55 mm  
 Расстояние между центром отверстия и стеной – 55 мм.

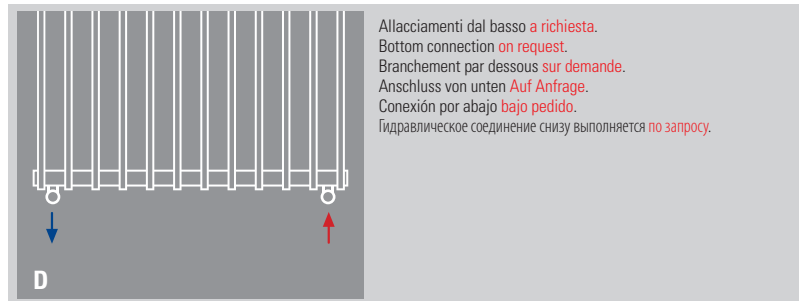
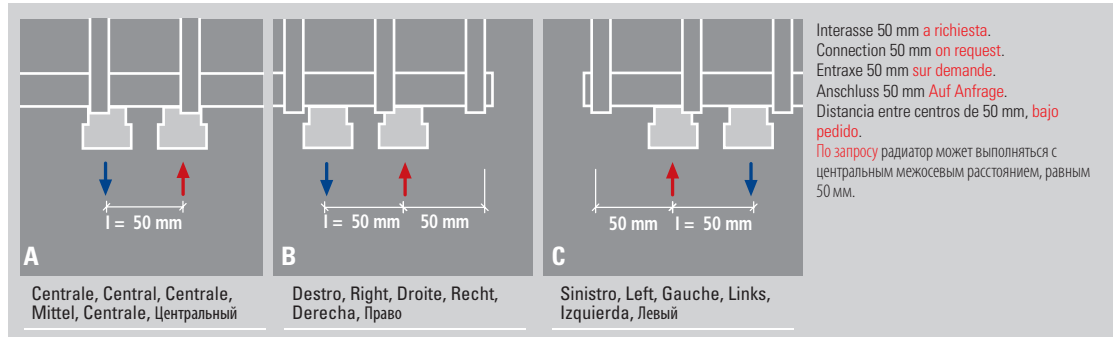

<p><b>Solo per i radiatori indicati è possibile, su richiesta, l'adattamento all'impianto monotubo.</b>                  La lavorazione speciale comporta un aumento del +10% dal prezzo indicato.</p>	<p><b>Only these radiators can be fitted for monotube connection on request.</b>                  For these special processing a +10% increase on price is required.</p>	<p><b>Seulement pour les radiateurs indiqués il est possible de prévoir sur demande l'adaptation pour la version monotube.</b>                  Pour cette opération il faut considérer une augmentation de 10% sur le prix indiqué.</p>	<p><b>Nur die angegebenen Heizkörper können auf Anfrage für den Anschluss zum Einrohrsystem gefertigt werden.</b>                  Für diese Sonderbearbeitung ist eine Preiserhöhung von den 10 % vorgesehen.</p>	<p><b>Sólo para estos radiadores es posible, bajo pedido, la adaptación para el sistema de calefacción monotubo.</b>                  Para este tratamiento especial se produce un aumento del + 10% desde el precio.</p>	<p><b>Только эти радиаторы могут быть установлены с однотрубным подключением по запросу.</b>                  Эта специальная опция увеличивает цену на 10%.</p>
--	--	--	--	---	--

# CIVETTA 35 SINGLE

codice code code Artikel Nr. codigoo код	n° elementi n° of elements no. des éléments Anzahl der Elemente no. elementos кол-во секций	larghezza width largeur Breite ancho ширина  L mm	Watt = Kcal/h ÷ 0,860 Kcal/h = Watt × 0,860											
			altezza . height . hauteur . Höhe . altura . высота											
			H mm	H mm	H mm	H mm	H mm	H mm	H mm	H mm	H mm	H mm	H mm	
			interasse . distance between bars . entraxe . Achsabstand . distancia entre centros . междунетровое расстояние											
			I mm	I mm	I mm	I mm	I mm	I mm	I mm	I mm	I mm	I mm	I mm	I mm
			360	460	560	760	960	1160	1460	1760	1960	2160	2360	
CV04S...	4	130	watt❖	79	94	116	152	180	216	268	320	356	392	424
CV05S...	5	165	watt❖	99	117	145	190	225	270	335	400	445	490	530
CV06S...	6	200	watt❖	119	140	174	228	270	324	402	480	534	588	636
CV07S...	7	235	watt❖	138	164	203	266	315	378	469	560	623	686	742
CV08S...	8	270	watt❖	158	187	232	304	360	432	536	640	712	784	848
CV09S...	9	305	watt❖	178	211	261	342	405	486	603	720	801	882	954
CV10S...	10	340	watt❖	198	234	290	380	450	540	670	800	890	980	1060
CV11S...	11	375	watt❖	217	257	319	418	495	594	737	880	979	1078	1166
CV12S...	12	410	watt❖	237	281	348	456	540	648	804	960	1068	1176	1272
CV13S...	13	445	watt❖	257	304	377	494	585	702	871	1040	1157	1274	1378
CV14S...	14	480	watt❖	277	328	406	532	630	756	938	1120	1246	1372	1484
CV15S...	15	515	watt❖	296	351	435	570	675	810	1005	1200	1335	1470	1590
CV16S...	16	550	watt❖	316	374	464	608	720	864	1072	1280	1424	1568	1696
CV17S...	17	585	watt❖	336	398	493	646	765	918	1139	1360	1513	1666	1802
CV18S...	18	620	watt❖	356	421	522	684	810	972	1206	1440	1602	1764	1908
CV19S...	19	655	watt❖	375	445	551	722	855	1026	1273	1520	1691	1862	2014
CV20S...	20	690	watt❖	395	468	580	760	900	1080	1340	1600	1780	1960	2120
CV21S...	21	725	watt❖	415	491	609	798	945	1134	1407	1680	1869	2058	2226
CV22S...	22	760	watt❖	435	515	638	836	990	1188	1474	1760	1958	2156	2332
CV23S...	23	795	watt❖	454	538	667	874	1035	1242	1541	1840	2047	2254	2438
CV24S...	24	830	watt❖	474	562	696	912	1080	1296	1608	1920	2136	2352	2544
CV25S...	25	865	watt❖	494	585	725	950	1125	1350	1675	2000	2225	2450	2650
CV26S...	26	900	watt❖	514	608	754	988	1170	1404	1742	2080	2314	2548	2756
CV27S...	27	935	watt❖	534	632	783	1026	1215	1458	1809	2160	2403	2646	2862
CV28S...	28	970	watt❖	553	655	812	1064	1260	1512	1876	2240	2492	2744	2968
CV29S...	29	1005	watt❖	573	679	841	1102	1305	1566	1943	2320	2581	2842	3074
CV30S...	30	1040	watt❖	593	702	870	1140	1350	1620	2010	2400	2670	2940	3180
CV32S...	32	1110	watt❖	632	749	928	1216	1440	1728	2144	2560	2848	3136	3392
CV34S...	34	1180	watt❖	672	796	986	1292	1530	1836	2278	2720	3026	3332	3604
CV36S...	36	1250	watt❖	711	842	1044	1368	1620	1944	2412	2880	3204	3528	3816
CV38S...	38	1320	watt❖	751	889	1102	1444	1710	2052	2546	3040	3382	3724	4028

<p>I radiatori sono completi di kit di fissaggio a parete e valvola di sfriato. Materiale: acciaio al carbonio. <b>La versione cromata NON è disponibile.</b> Pressione di collaudo: 5,2 bar Pressione di esercizio: 4 bar ❖ I watt hanno valori provvisori in attesa di certificazione Δt50.</p>	<p>The radiators are equipped with a kit for fixing them to the wall and with an exhaust valve. Material: carbon-steel. <b>Chromate radiators NOT available.</b> Testing pressure: 5,2 bar Working pressure: 4 bar ❖ The watt values are not definitive awaiting for Δt50 certification.</p>	<p>Les radiateurs sont munis d'un kit de fixation murale et d'une soupape de décompression. Matière: Acier au charbon. <b>La version chromée N'EST PAS disponible.</b> Pression d'essai: 5,2 bars Pression d'exercice: 4 bars ❖ Le nombre de Watts est une valeur indiquée à titre provisoire dans l'attente de la certification Δt50.</p>	<p>Die Heizkörper sind mit Wandbefestigungsset und Luftventil ausgerüstet. Stoff: Kohlenstoffstahl. <b>Die verchromte Version ist NICHT verfügbar.</b> Prüfungsdruck: 5,2 bar Betriebsdruck: 4 bar ❖ Die Wattwerte sind noch provisorisch in Erwartung von Δt50 Zertifizierung. <b>Für die hydraulisc</b></p>	<p>Los radiadores están provistos de kit de fijación a la pared y de válvula de desahogo. Material: Acero de carbono. <b>La versión cromada NO está disponible.</b> Presión de ensayo: 5,2 bar Presión de trabajo: 4 bar ❖ Los Váticos tienen valores provisionales en espera de la certificación Δt50.</p>	<p>Радиаторы укомплектованы набором крепежных деталей для закрепления на стене и выпускным клапаном. Материал – углеродистая сталь. <b>Хромированная версия в продаже ОТСУТСТВУЕТ.</b> Давление при испытании – 5,2 бар Рабочее давление – 4 бар ❖ До получения сертификата Δt50 приводится предварительное значение мощности в ваттах.</p>
---	--	--	---	---	---

# CIVETTA 35 DOUBLE

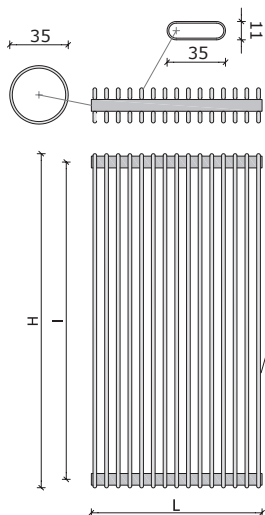

tubi min 4 / max 38  
 pipes min 4 / max 38  
 tuyaux min 4 / max 38  
 rohre min 4 / max 38  
 tubos min 4 / max 38  
 трубы мин. 4 / макс. 38

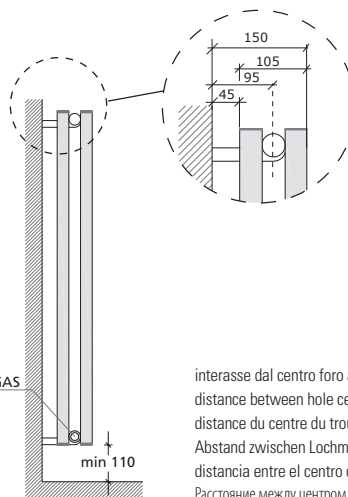

interasse dal centro foro al muro 95 mm  
 distance between hole center and wall 95 mm  
 distance du centre du trou au mur 95 mm  
 Abstand zwischen Lochmitte und Wand 95 mm  
 distancia entre el centro del agujero y el muro 95 mm  
 Расстояние между центром отверстия и стеной – 95 мм.

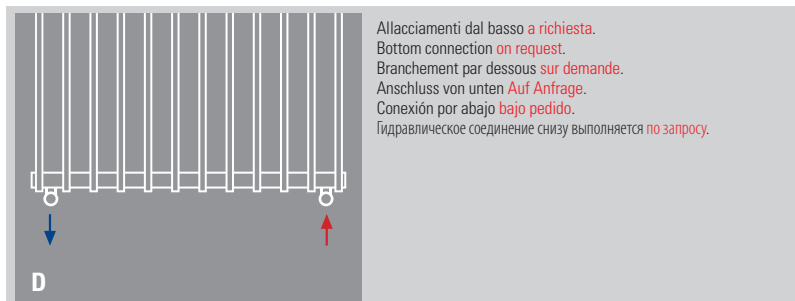
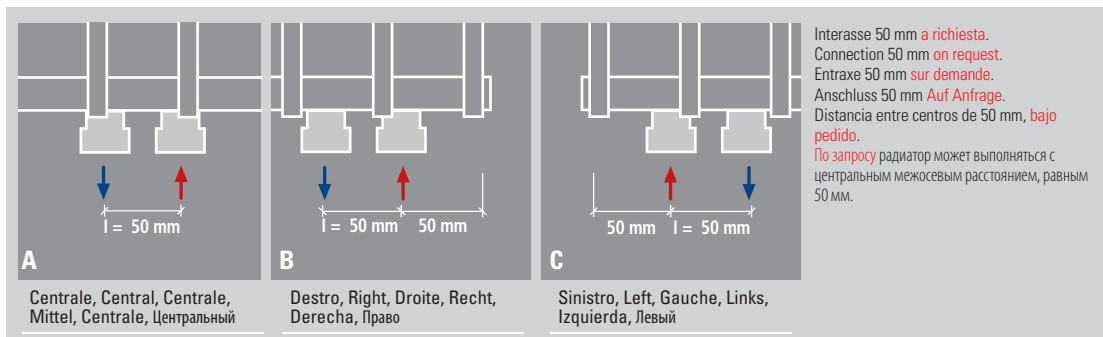
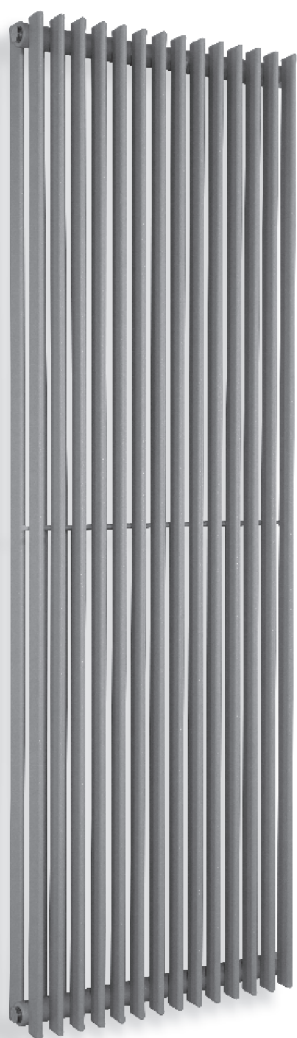

<p><b>Solo per i radiatori indicati è possibile, su richiesta, l'adattamento all'impianto monotubo.</b>                  La lavorazione speciale comporta un aumento del +10% dal prezzo indicato.</p>	<p><b>Only these radiators can be fitted for monotube connection on request.</b>                  For these special processing a +10% increase on price is required.</p>	<p><b>Seulement pour les radiateurs indiqués il est possible de prévoir sur demande l'adaptation pour la version monotube.</b>                  Pour cette opération il faut considérer une augmentation de 10% sur le prix indiqué.</p>	<p><b>Nur die angegebenen Heizkörper können auf Anfrage für den Anschluss zum Einrohrsystem gefertigt werden.</b>                  Für diese Sonderbearbeitung ist eine Preiserhöhung von den 10 % vorgesehen.</p>	<p><b>Sólo para estos radiadores es posible, bajo pedido, la adaptación para el sistema de calefacción monotubo.</b>                  Para este tratamiento especial se produce un aumento del + 10% desde el precio.</p>	<p><b>Только эти радиаторы могут быть установлены с однотрубным подключением по запросу.</b>                  Эта специальная опция увеличивает цену на 10%.</p>
--	--	--	--	---	--



# COLIBRÌ DOUBLE

codice code code Artikel Nr. codigo код	altezza height hauteur Höhe altura высота	larghezza width largeur Breite ancho ширина	interasse distance between bars entraxe Achsabstand distancia entre centros межцентровое расстояние	Watt = Kcal/h ÷ 0,860 Kcal/h = Watt × 0,860		
				output - verniciato output - painted output - peint Output - lackiert output - pintado мощность - окрашенный	75/65-20 watt/kcal/h ♦ Δt50	55/45-20 watt/kcal/h ♦ Δt30
410632	682	410	360	587	300	253
510632	682	510	460	712	378	316
610632	682	610	560	756	401	336
760632	682	760	710	850	458	385
411132	1132	410	360	877	448	378
511132	1132	510	460	1061	560	469
611132	1132	610	560	1245	723	605
761132	1132	760	710	1484	788	660
411432	1406	410	360	1144	584	492
511432	1406	510	460	1362	712	594
611432	1406	610	560	1553	816	681
761432	1406	760	710	1770	939	787
411732	1706	410	360	1334	681	574
511732	1706	510	460	1638	843	700
611732	1706	610	560	1952	1020	851
761732	1706	760	710	2268	1210	1015



♦ I watt hanno valori provvisori in attesa di certificazione Δt50.	♦ The watt values are not definitive awaiting for Δt50 certification.	♦ Le nombre de Watts est une valeur indiquée à titre provisoire dans l'attente de la certification Δt50.	♦ Die Wattwerte sind noch provisorisch in Erwartung von Δt50 Zertifizierung.	♦ Los Vattios tienen valores provisionales en espera de la certificación Δt50.	♦ До получения сертификата Δt50 приводится предварительное значение мощности в ваттах.
--	---	--	--	--	--

I radiatori sono completi di kit di fissaggio a parete e valvola di sfogo. Materiale: acciaio al carbonio. Pressione di collaudo: 10,5 bar Pressione di esercizio: 7 bar <b>La versione cromata NON è disponibile.</b>	The radiators are equipped with a kit for fixing them to the wall and with an exhaust valve. Material: carbon-steel. Testing pressure: 10,5 bar Working pressure: 7 bar <b>Chromed radiators NOT available.</b>	Les radiateurs sont munis d'un kit de fixation murale et d'une soupape de décompression. Matière: Acier au charbon. Pression d'essai: 10,5 bars Pression d'exercice: 7 bars <b>La version chromée N'EST PAS disponible.</b>	Die Heizkörper sind mit Wandbefestigungsset und Luftventil ausgerüstet. Stoff: Kohlenstoffstahl. Prüfungsdruck: 10,5 bar Betriebsdruck: 7 bar <b>Die verchromte Version ist NICHT verfügbar.</b>	Los radiadores están provistos de kit de fijación a la pared y de válvula de desahogo. Material: Acero de carbono. Presión de ensayo: 10,5 bar Presión de trabajo: 7 bar <b>La versión cromada NO está disponible.</b>	Радиаторы укомплектованы набором крепежных деталей для закрепления на стене и выпускным клапаном. Материал – углеродистая сталь. Давление при испытании – 10,5 бар Рабочее давление – 7 бар <b>Хромированная версия в продаже ОТСУТСТВУЕТ.</b>
--	---	---	--	--	--